



This reference covers the following Fadal products:

Model TRM

Corporate Officevoice (818) 407-1400 fax (818) 407-0020
Service / Partsvoice (818) 727-2100 fax (818) 407-1004
Programming Supportvoice (818) 727-2100 fax (818) 407-0061

support@fadal.com

20701 Plummer Street Chatsworth California 91311 U.S.A.

The content of this manual has been reviewed for accuracy and is applicable to current Fadal hardware and software products as described herein. Differences may exist and we cannot guarantee that they are completely covered in this document. The information in this document is reviewed regularly and any necessary changes will be incorporated in the next revision. We welcome any suggestions for improvement.

Material is subject to change without notice.

This manual is for the exclusive use of Fadal Customers and Distributors. The reproduction, transmission or use of this document or its contents is not permitted without the expressed written permission of Fadal Machining Centers. All rights, including rights created by patent grant or registration of a utility, model or design, are reserved.

© Copyright 2003 Fadal Machining Centers.

This page intentionally left blank.

SHEET METAL ASSEMBLY

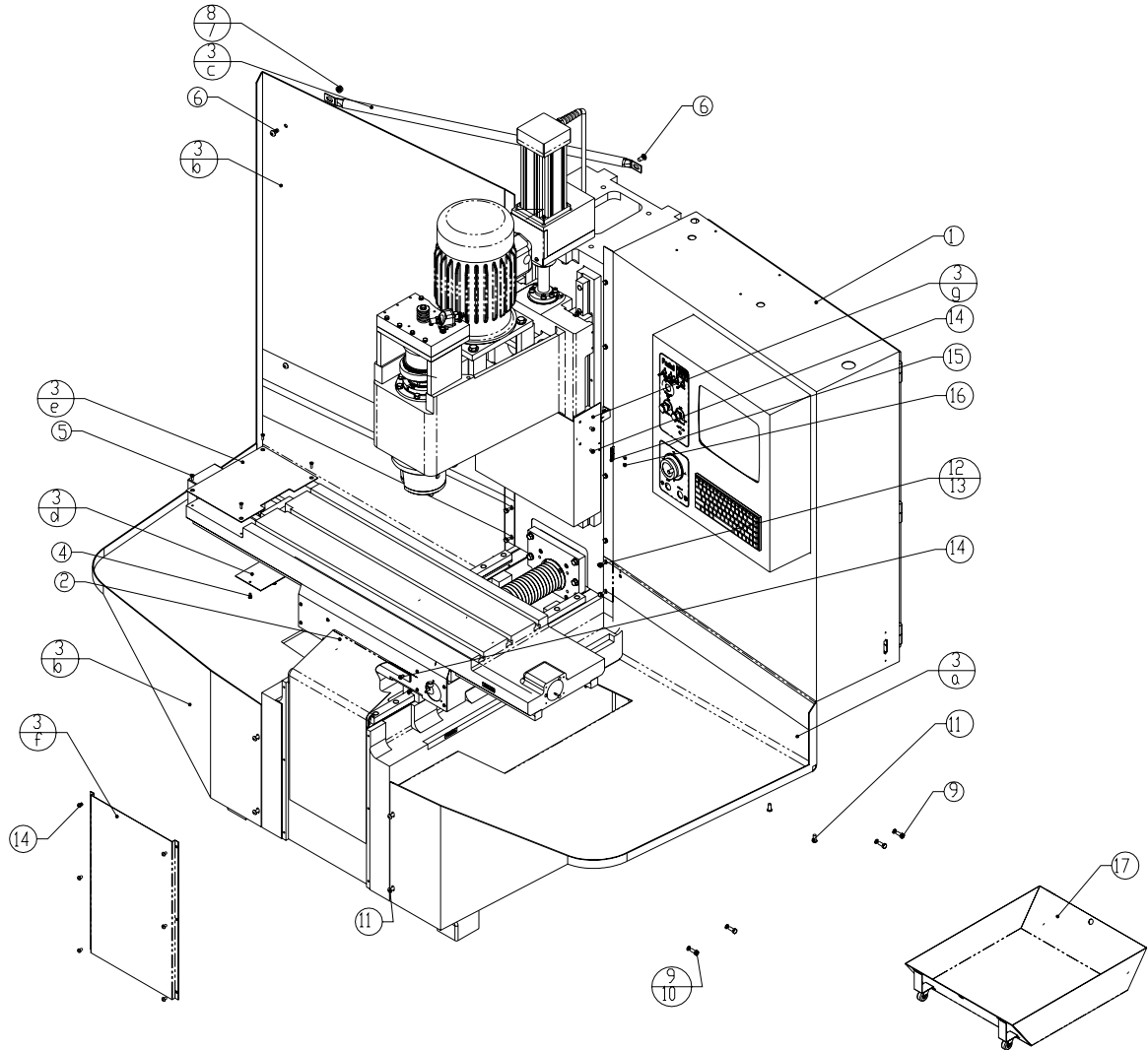

ITEM NO.	QTY.	PART NO.	DESCRIPTION
1	1	FMC_0141_Mechanical_Floor_Assembly_TRM	
2	1	CVR_0261_Front_Cover_Assembly_TRM	
3	1	STM_1817_Sheetmetal_Kit_Assembly_TRM	
a	1	Stm_1643_Sheet_Metal_Right_Side_Low_Profile_Trm	
b	1	Stm_1642_Sheet_Metal_Left_Side_Low_Profile_Trm	
c	2	STM_1636_Support_Bracket_Trm	
d	1	STM_1816_Coupler_Cover	
e	1	STM_1734_BallScrew_Cover	
f	1	STM_1687_Sheet_Metal_Cover_Trm	
g	1	STM_1640_cover_head_z_axis_trm	
4	2	Hdw_0348_screw_button_socap_10_32x.5	18-8 Stainless Steel
5	4	Hdw_0324_Flat_Head_SCS_#10_-32 UNF x 1/2	Alloy Steel Black Finish
6	4	HDW_0345_Screw 3/8_-16 UNC x 3/4, BTN SHCS PLN	18-8 Stainless Steel
7	2	HDW-0280	SPLIT LOCK WASHER 3/8 SS
8	2	HDW_0333_Nut 3/8_-16 FIN HX Full	18-8 Stainless Steel
9	8	Hdw_0575_screw_hexcap_gr8_3125_18x.75	Zinc-Plated Steel, Grade 5 Medium Strength
10	8	HDW-0281	SPLIT LOCK WASHER 5/16
11	8	HDW_1028_Button_Head_SCS_0.3125_-18 UNC x 3/4"	18-8 Stainless Steel
12	9	HDW-0319	HEXCAP SCREW GR8 1/4X20 1/2LONG Zinc Pl.
13	9	HDW-0279	LOCK SPLIT WASHER 1/4
14	9	HDW-0347	BUTTON SCREW SOCAP 1/4X20 3/8LONG
15	1	Stm_0593_cold_start_brkt_x_axis_l_model	
16	2	Hdw_0352_screw_button_socap_8_32x.25	18-8 Stainless Steel
17	1	STM_1623_Chip_Tank_Assembly_TRM	

MECHANICAL ASSEMBLY

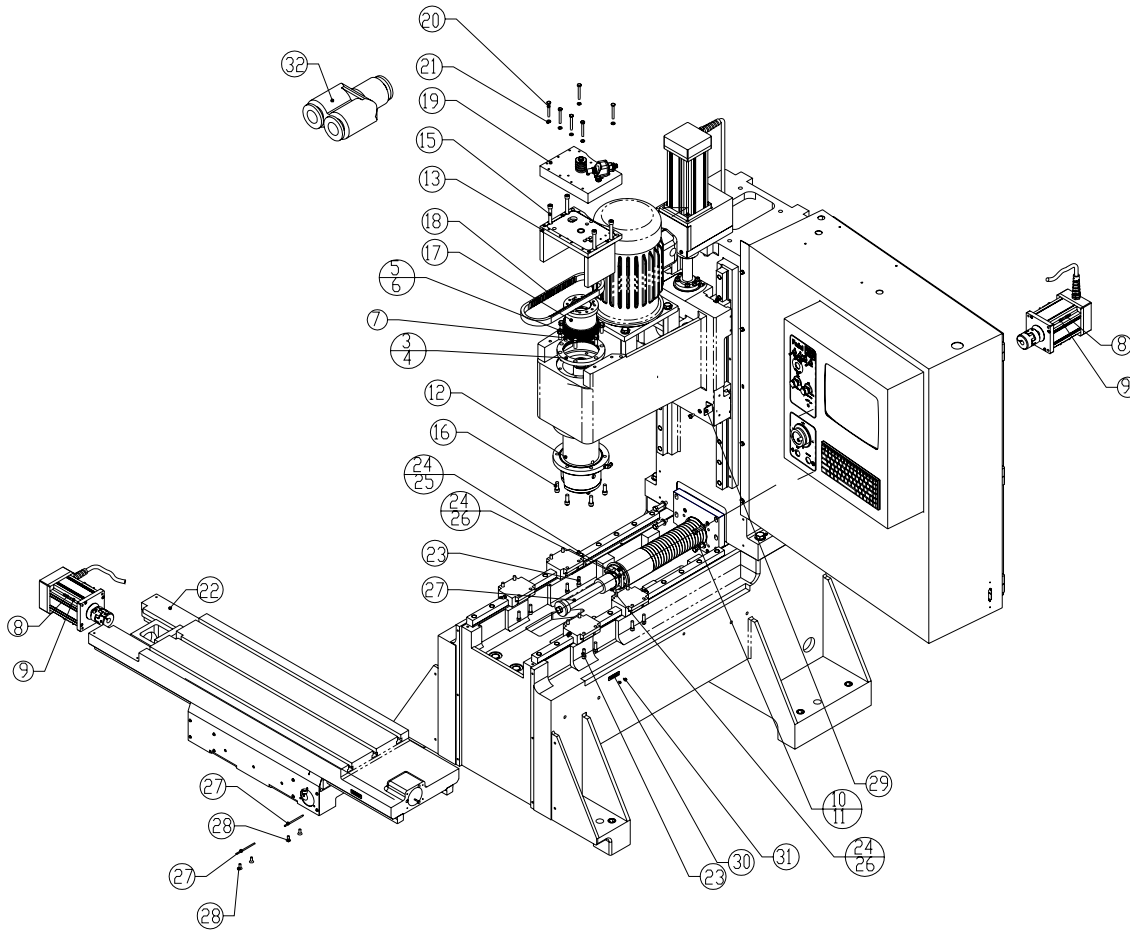

ITEM NO.	QTY.	PART NO.	DESCRIPTION
ITEM NO.	QTY.	PART NO.	DESCRIPTION
1	1	FMC_0140_Pre-Assembly_TRM	
2	1	Bls_0377_Ballscrew_Asy_Y_Axis_Trm	
3	1	SPN_0042 Retainer spindle upper	
4	1	HDW_0170 O ring 2-247	
5	6	Hdw_0568_screw_hexcap_gr8_375_16x1	Zinc-Plated Steel, Grade 5 Medium Strength, ANSI/ASME thread
6	6	Hdw_0275_washer_390x625x060_fw_ylw_zc	
7	1	HDW_0422 Plug_pressure_125 x 18	
8	8	HDW-0301 Screw Socap 10-32 x 1.00	Alloy Steel Black Finish
9	8	Hdw_0278_washer_lock_split_#10_z_p	18-8 Stainless Steel
10	4	HDW-0569	HEXCAP SCREW GR8 3/8X16 1 3/4 LONG ZINC PL
11	4	Hdw-0049 Washer,Hardened:3/8	Zinc-Plated Steel
12	1	SPN_0081_spindle_assy_non-lock_7.5K_grease	
13	1	ORB_0040_Orient_Bridge_Asy_Trm	
14	1	Hdw_0093	
15	4	Hdw_0288_screw_socap_375_16x5.25	Alloy Steel Black Finish
16	6	Hdw_0470_screw_socap_375_16x1	Alloy Steel Black Finish
17	1	PUL_0025_SPRKT_SPN_PLYCHN_NON_COOLANT	
18	1	BEL-0039_BELT_GATES_TRM	
19	1	DRB_0049_Drawbar_Cylinder_Asy_Standart	
20	6	Hdw_0320_screw_hexcap_gr8_25_20x2	Zinc-Plated Steel, Grade 5 Medium Strength, ANSI/ASME thread
21	6	HDW-0279	LOCK SPLIT WASHER 1/4
22	1	SDL_0089 SDL_TBL_BSCREW_ASSEMBLY TRM	
23	16	Hdw_0481_screw_socap_0.3125 -18 UNC x 1	Alloy Steel Black Finish
24	6	Hdw_0291_screw_socap_3125-18x1_25	Alloy Steel Black Finish
25	4	Hdw_0048_washer_hardened_3125	Zinc-Plated Steel
26	2	HDW-0281	SPLIT LOCK WASHER 5/16
27	2	HDW_1284_press_roller_linear_carriage EMC 2016L 3016L	
28	4	Hdw_0503_250-20x.500_FHSCS	Alloy Steel Black Finish
29	1	Stm_0048_z_axis_c_s	
30	1	Stm_0593_cold_start_brkt_x_axis_l_model	
31	2	Hdw_0352_screw_button_socap_8_32x.25	18-8 Stainless Steel
32	1	PLM_0201 Fitting, 5/32 x 5/32 QD "Y"	

FINISHED ASSEMBLY

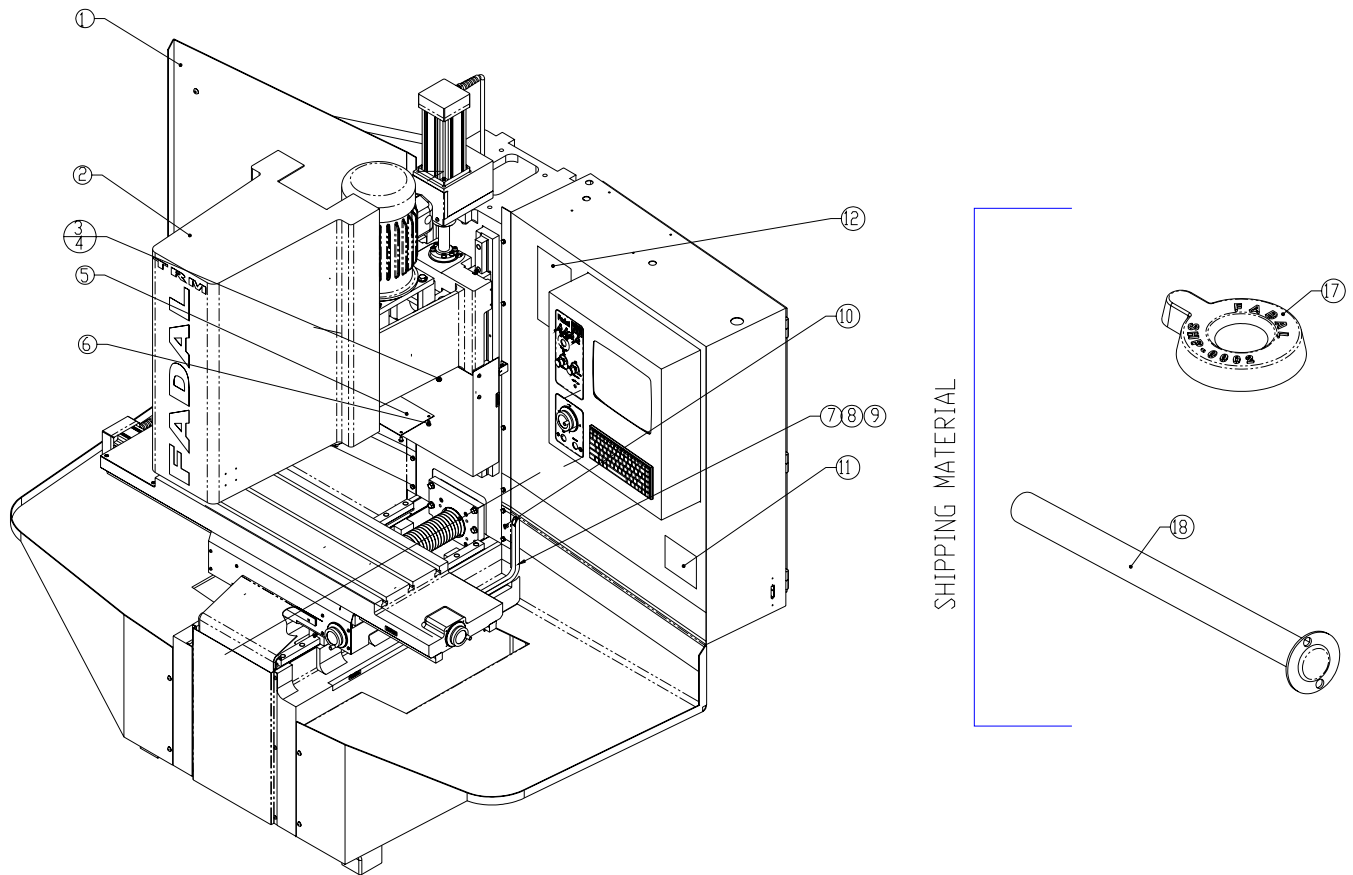

* See page 6 for the B.O.M.

FINISHED ASSEMBLY

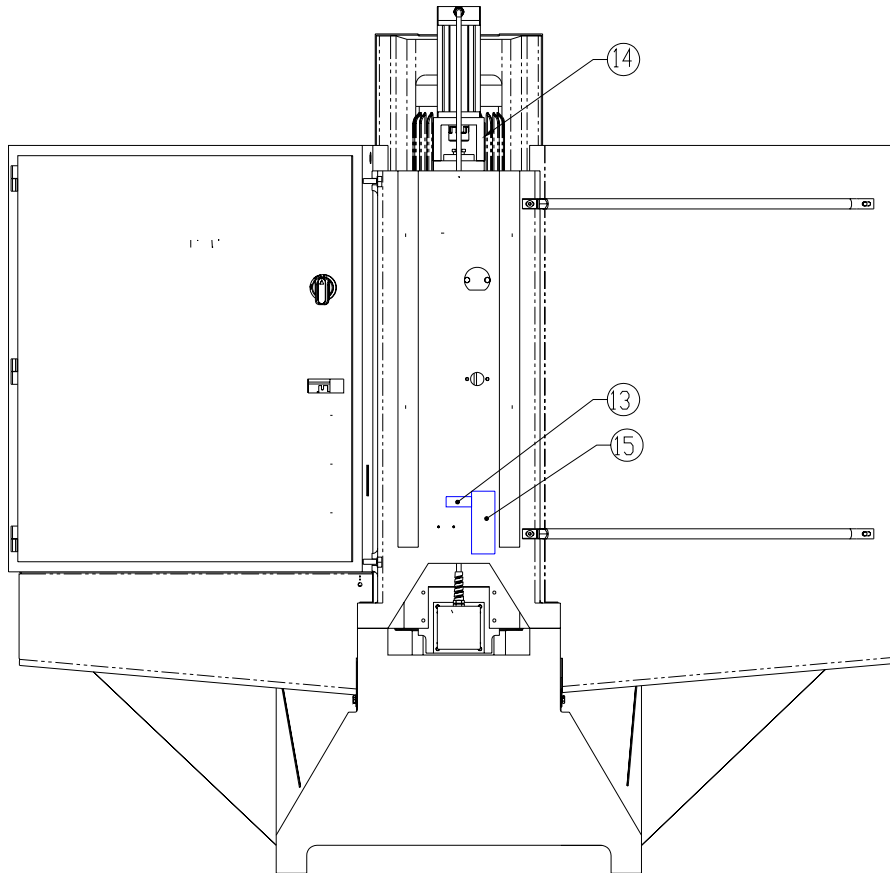

ITEM NO.	QTY.	PART NO.	DESCRIPTION
1	1	FMC_0142_Sheetmetal_Assembly_TRM	
2	1	Cvr-0262 Head_Cover_Assembly_TRM	
3	4	Hdw_0322_screw_hexcap_gr8_25_20x.75	Zinc-Plated Steel, Grade 5 Medium Strength
4	4	HDW-0047	WASHER HARDENED 1/4
5	1	Stm_0064_cover_head_core_all_vmc	
6	4	Hdw_0795_screw_hexcap_gr8_25_20x.375	Zinc-Plated Steel, Grade 5 Medium Strength
7	1	STM_1834_Cable_Carrier_Bracket	
8	1	HDW_1028_Button_Head_SCS_0.3125_-18 UNC x 3/4"	18-8 Stainless Steel
9	1	CVR_0260_Cable_Carrier_TRM	
10	4	HDW-0606 Screw 6-32 x .500 FSHCS PLN	Alloy Steel Black Finish
11	1	LBL_0213 Lbl-Made in USA	
12	1	LBL_0123 Safety label, instructions	
13	1	LBL_0146 Air Pressure Label	
14	1	LBL_0471 LBL, Danger, Z-Axis Fall SPN	
15	1	LBL_0126 Warning Lable, Air Pressure	
16	1	Serial Number Lable	
17	6	SHP_0002 Leveling Pad, FADAL	
18	1	HDW_1000 Rod Cap/Counter Weight Pin	

SHEET METAL KIT

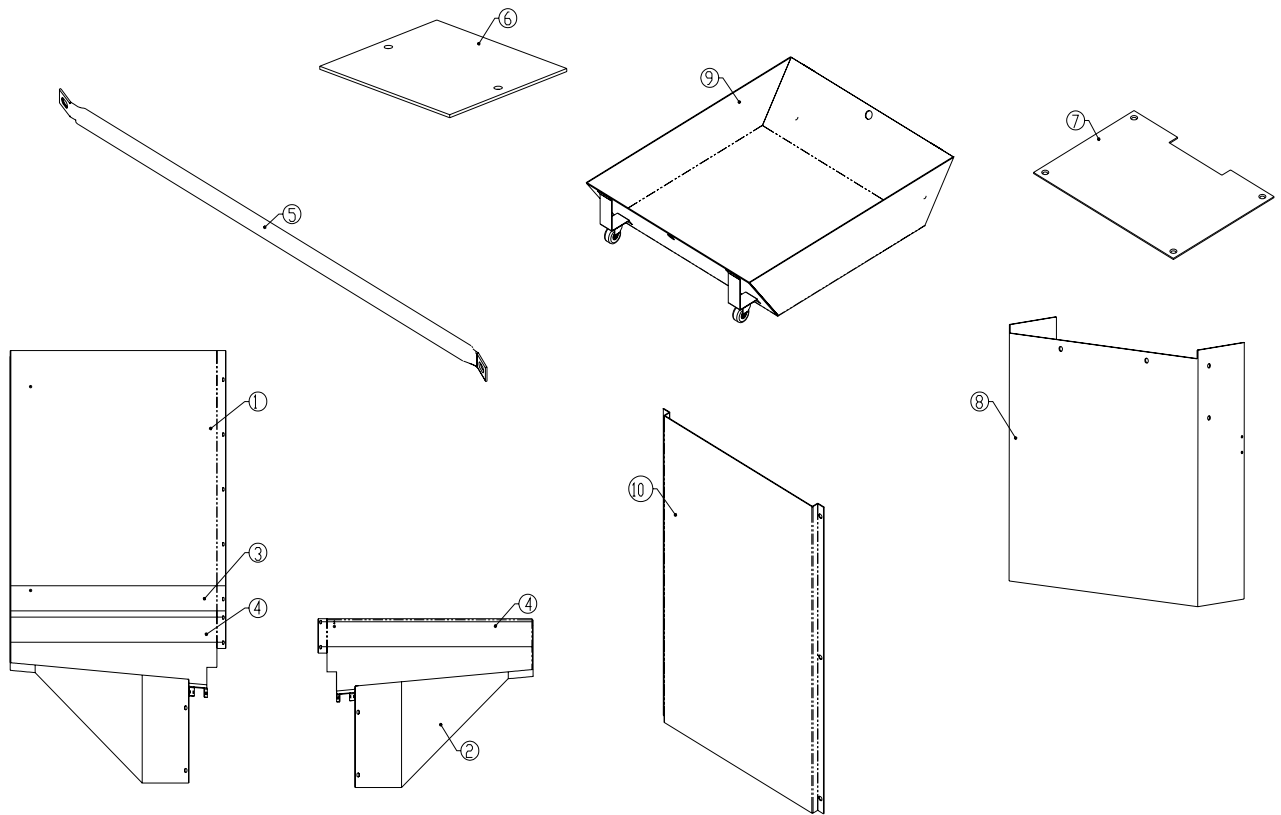

ITEM NO.	QTY.	PART NO.	DESCRIPTION
1	1	STM-1642	SHEET METAL LEFT SIDE, TRM
2	1	STM-1643	SHEET METAL RIGHT SIDE, TRM
3	1	LBL-0496	VINYL VIVID DARK BLUE, 4.0inches x 4.0feet
4	2	LBL-0504	VINYL OLYMPIC LIGHT BLUE, 4.0inches x 4.0feet
5	2	STM-1636	SUPPORT BRACKET, TRM
6	1	STM-1816	COUPLER COVER
7	1	STM-1734	BALLSCREW COVER
8	1	STM-1640	COVER HEAD Z AXIS, TRM
9	1	STM-1623	CHIP TANK ASSEMBLY, TRM
10	1	STM-1687	SHEETMETAL COVER, TRM

HEAD COVER ASSEMBLY

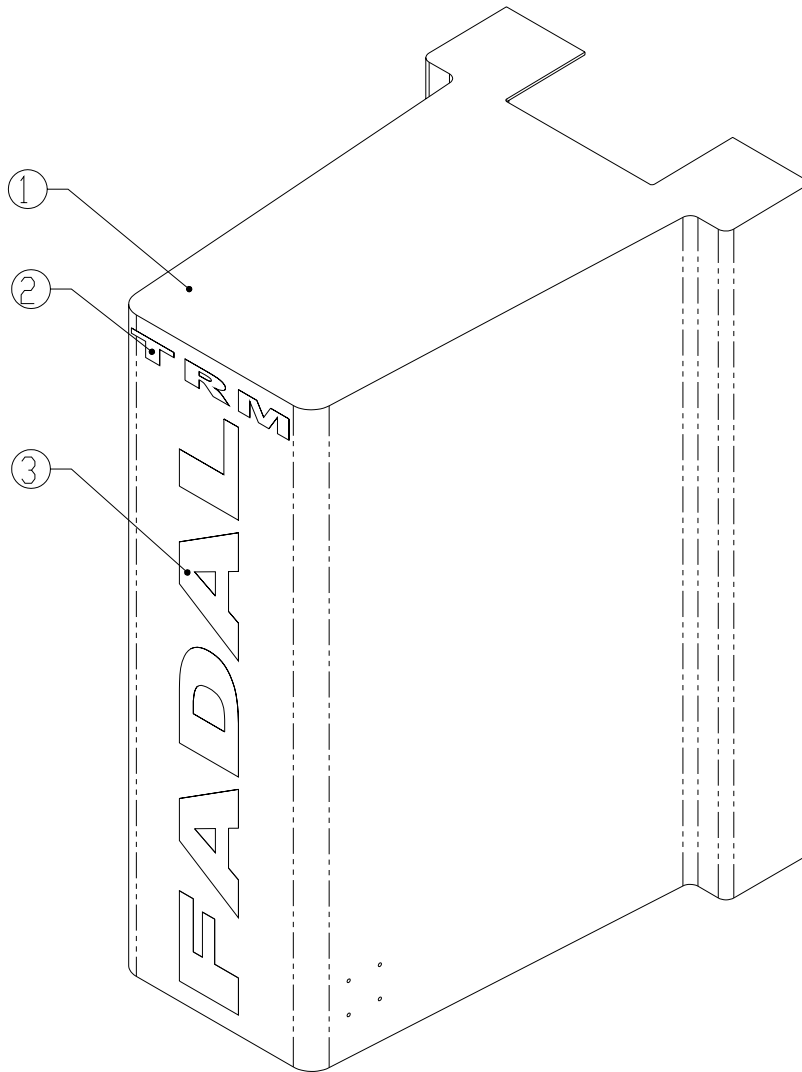

ITEM NO.	QTY.	PART NO.	DESCRIPTION
1	1	CVR-0251	COVER, HEAD, TRM
2	1	LBL-0505	LETTER: "TRM", TRM
3	1	LBL-0495	LETTER: "FADAL", TRM

MOTOR ASSEMBLY

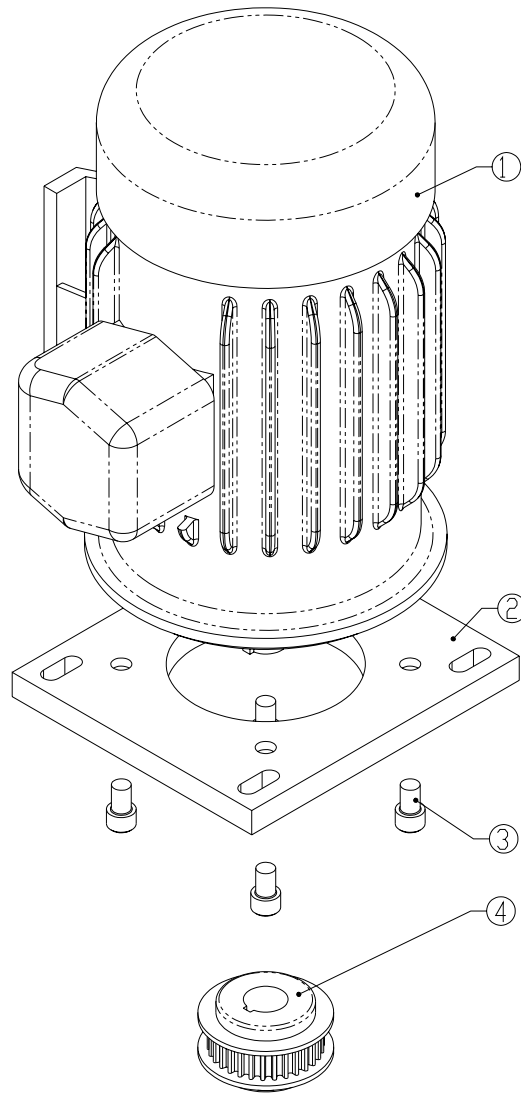

ITEM NO.	QTY.	PART NO.	DESCRIPTION
1	1	MTR_0232 baldor motor	
2	1	MTR_0226 Plate Spindle_Motor Mount TRM	
3	4	Hdw_0283 Socket Head Cap Screw .500-13x.750 Alloy Steel Black Finish	
4	1	PUL-0078 Sprcket MTR Polychain TRM	

COLUMN / BASE ASSEMBLY

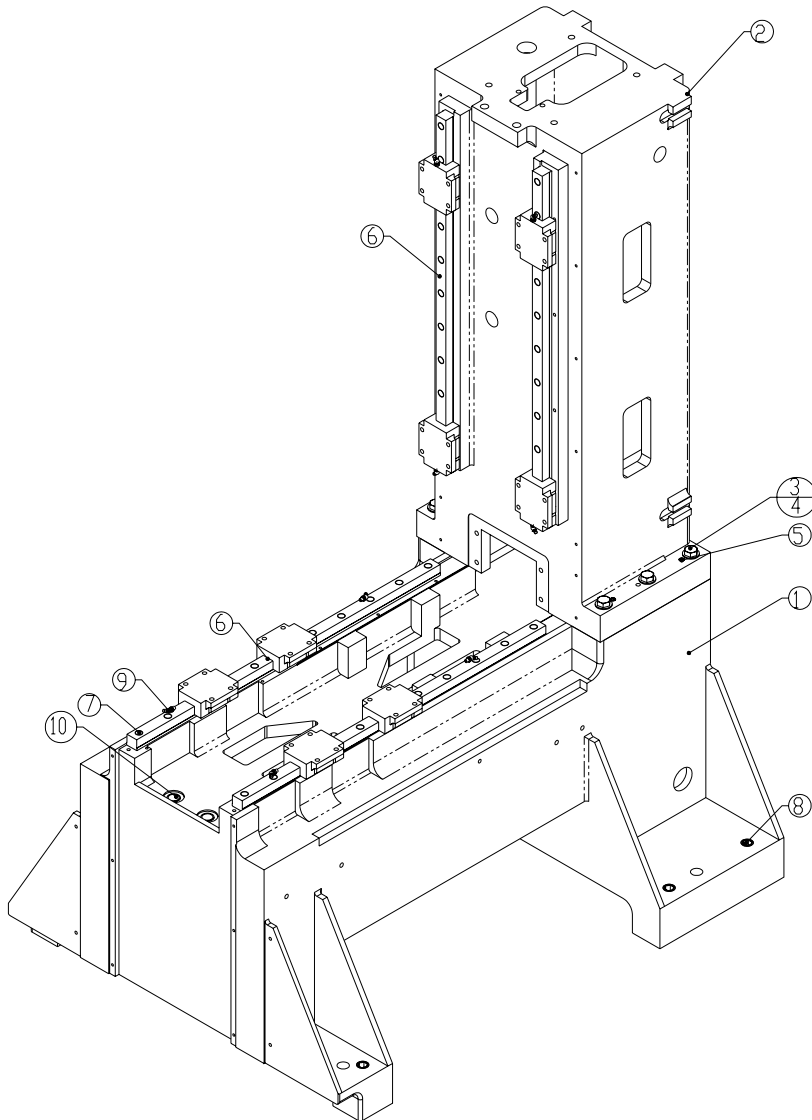

ITEM NO.	QTY.	PART NO.	DESCRIPTION
1	1	BAS-0050	Base Machined LP TRM
2	1	COL-0050	Column Machined LP TRM
3	6	Hdw-0555	Screw Hexcap 5/8-11 x 3.50
4	6	Hdw-0051	Washer Hardened 5/8
5	4	Hdw-0769	Screw Set Halfdog 1/2-20 x 1.00
6	4	BRG-0173	Linear Rail Y Axis, Z Axis, TRM
7	44	Hdw-0291	Screw Socap 5/16-18 x 1 1/4
8	6	Hdw-0432	Screw Set 1.00-14 x 3.00
9	8	P1m-0245	Fttnng H drlc Grs M6x1 Mle 45deg
10	2	Hdw-1318	Plug Plastic Red

BASE ASSEMBLY

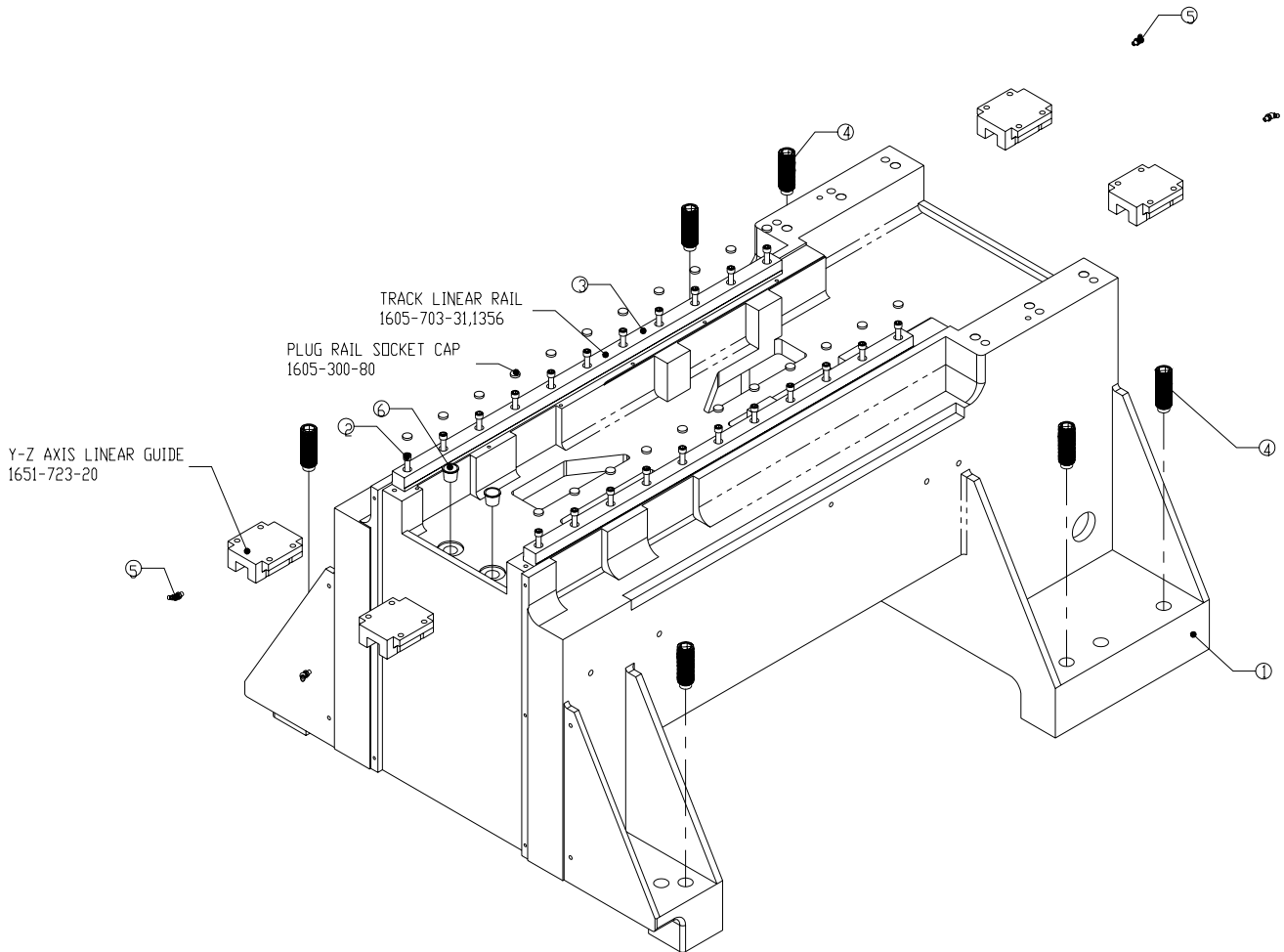

ITEM NO.	QTY.	PART NO.	DESCRIPTION
1	1	BAS-0050	Base Machined LP TRM
2	22	HDW0291	Screw Socap 5/16-18 x 1 1/4
3	2	BRG-0173	Linear Rail Y Axis, Z Axis, TRM
	1	1605-703-31,1356	Y-Z Axis Linear Guide TRM
	2	1651-723-20	Truck Linear Rail TRM
	22	1605-300-80	Plugs Rail Socket Cap
4	6	HDW0432	Screw Set 1.00-14x3.00
5	4	PLM-0245	Fitting Hdric Grs M6x1 Me 45deg
6	2	HDW-1318	Plugs Plastic Red

COLUMN ASSEMBLY

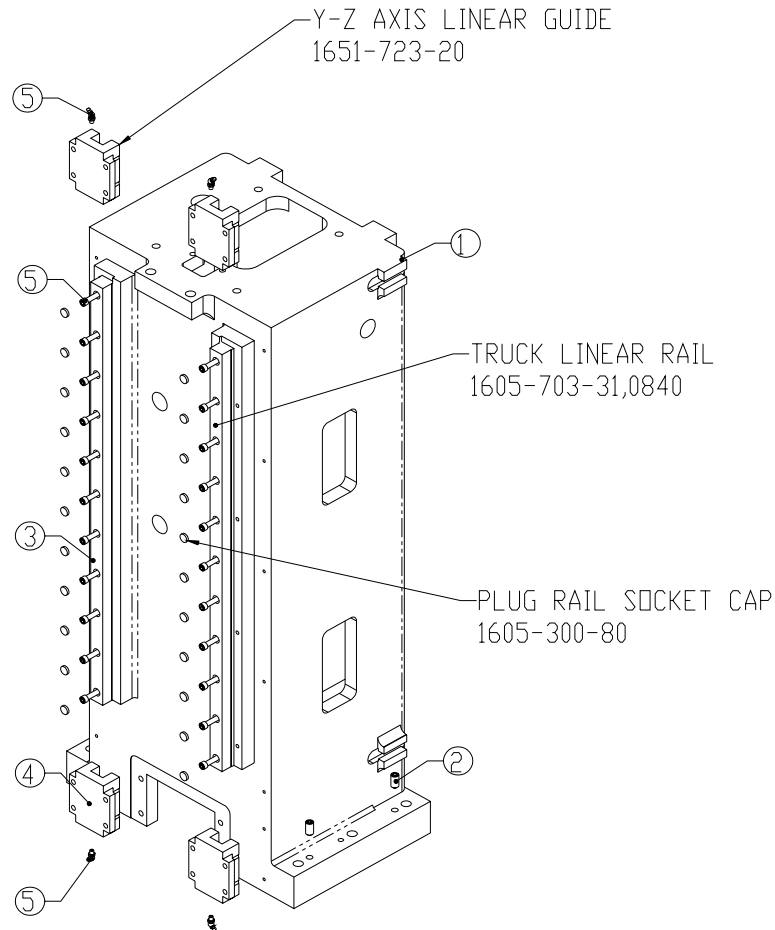

ITEM NO.	QTY.	PART NO.	DESCRIPTION
1	1	COL-0050	Column Machined LP TRM
2	4	HDW-0769	Screw Set Halfdog 1/2-20 x 1.00
3	2	BRG-0173	Linear Rail Y Axis, Z Axis, TRM
	1	1605-703-31,1356	Y-Z Axis Linear Guide TRM
	2	1651-723-20	Truck Linear Rail TRM
	22	1605-300-80	Plugs Rail Socket Cap
4	22	HDW-0291	Screw Socap 5/16-18 x 1 1/4
5	4	PLM-0245	Ftting Hdrlic Grs M6x1 Mle 45deg

